



PCE Americas Inc.
711 Commerce Way
Suite 8
Jupiter
FL-33458
USA
From outside US: +1
Tel: (561) 320-9162
Fax: (561) 320-9176
info@pce-americas.com

PCE Instruments UK Ltd.
Unit 11
Southpoint Business Park
Ensign way
Hampshire / Southampton
United Kingdom, SO31 4RF
From outside UK: +44
Tel: (0) 2380 98703 0
Fax: (0) 2380 98703 9
info@industrial-needs.com

www.pce-instruments.com/english
www.pce-instruments.com

Temperature Meter PCE-IR10 INSTRUCTION MANUAL

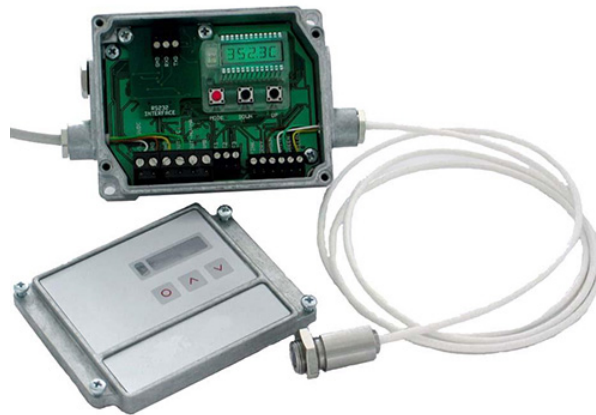

CE-Conformity



The product complies with the following standards:

EMC: EN 61326-1
Safety Regulations: EN 61010-1:1993/ A2:1995

The product accomplishes the requirements of the EMC Directive 89/336/EEC and of the low-voltage directive 73/23/EEC.

Scope of supply

- PCE-IR10 electronic box,
- pre-installed sensing head (cable length according to order),
- operators manual

You will find the serial number on a label on the electronic box. The cable is labeled with the serial number of the head.

Always use these numbers when you contact the customer service concerning maintenance, additional order of components, spare parts or repairs.

Content

		Page
1	Quick Reference	5
2	Technical Data	10
2.1	General Specifications	10
2.2	Electrical Specifications	11
2.3	Measurement Specifications	12
2.4	Optical Charts	13
2.5	CF-Optics	14
3	Mechanical Installation	16
4	Electrical Installation	19
4.1	Cable Connections	19
4.2	Exchange of the Sensing Head	21
4.3	Outputs	22
4.4	Digital Interfaces	23
4.5	Functional Inputs	25
5	Operation	26
6	Software CTconnect	29
6.1	Installation	29

6.2	Starting the Software	30
6.3	Diagram Functions	31
6.4	Configuration of the PCE-IR10	37
6.4.1	Signal Processing	38
6.4.2	Output Signals	45
6.4.3	Advanced Settings	48
7	Principle of Operation	50
8	Emissivity	51
9	Maintenance	52
	Appendix A – Visual Alarms	53
	Appendix B – Emissivity Tables	54

1 Quick Reference

Thank you for choosing the PCE-IR10 infrared sensor.

In this chapter you will find concentrated information for a quick start with the PCE-IR10 sensor.

Comments to this manual

Read the manual carefully before the initial start-up.

You will find **important information and notes** in the grey coloured boxes.

IMPORTANT

The producer reserves the right to change the herein described specifications in case of technical advance of the product.

Mechanical Installation

PCE-IR10 heads are equipped with a metrical M12x1-thread and can be installed either directly via the sensor thread or with the help of the hex nut (delivered as standard) to the mounting bracket available.

Various mounting brackets, which make the adjustment of the sensing head easier, can be additionally ordered as accessories. Make sure to keep the optical path clear of any obstacles when adjusting the head to the object (see chapter 2.4).

► **More information in chapter 3**

**The sensing head is a sensitive optical system. Please use only the thread for mechanical installation.
Avoid mechanical violence on the head – this may destroy the system (expiry of warranty).**

Electrical Installation

Please open at first the cover of the PCE-IR10 electronic box (4 screws). Below the display are the screw terminals for the cable connection.

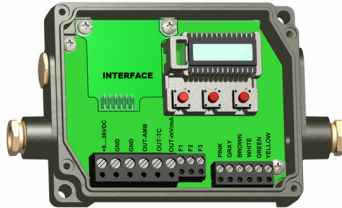

Use shielded cables only. The sensor shield has to be grounded.

Please use a power supply unit with an output voltage of **8 – 36 VDC/ 100 mA**.

The standard delivery includes the connected cable of the sensing head to the electronic box. You may shorten but never lengthen the cable.

► **More information in chapter 4.1**

Head exchange

Sensing heads of the PCE-IR10 series are exchangeable. Every head has a specific **calibration code**, which is printed on the head cable. For a correct temperature measurement and functionality of the PCE-IR10 this calibration data must be stored in the electronic box. The calibration code consists of **three blocks** with **4 characters** each.

Example: **EKJO – OUD – OA1B**
 block 1 block 2 block 3

For entering the code please press the **Up**- and **Down**-key (keep pressed) and *then* the **Mode**-key. The display shows **HCODE** and then the 4 signs of the first block. With **Up** and **Down** each sign can be changed, **Mode** switches to the next sign or next block.



You will find the calibration code on a label fixed on the head cable (near the electronic box). If you shorten the cable, please make sure to note the calibration code. The code is needed if the head will be changed.

► **More information in chapter 4.2**

Analog Outputs

You can select the desired analog output via the programming keys (see Tab. 5-1).

Output	Range	Connection-Pin on PCE-IR10-Board
Voltage	0 ... 5 V	OUT-mV/mA
Voltage	0 ... 10 V	OUT-mV/mA
Current	0 ... 20 mA	OUT-mV/mA
Current	4 ... 20 mA	OUT-mV/mA
Thermocouple	TC J	OUT-TC
Thermocouple	TC K	OUT-TC

According to the chosen output signal there are different connection pins on the PCE-IR10 board (**OUT-mV/mA** or **OUT-TC**).

Factory default setting is 0-5 V (temperature range 0-500 °C).

► **More information in chapter 4.3**

Digital Interfaces (optional)

If you want to install an interface, please do the following:

- plug the interface board into the place provided, which is located beside the display
- use both M3x5 screws for fixing it onto the electronic box
- plug the preassembled interface cable with the terminal block into the male connector of the interface board

If you use the USB-interface, the PCE-IR10 needs no external power supply for operation – it will be powered by the USB-interface.

Please install the software CTconnect as described in chapter 6.1.

► **More information in chapter 4.4**

If you use the USB-interface board or the RS232-interface board and your own RS232-to-USB-adaptor you will see the COM port as a **virtual COM port (VCP)** in your system. During the installation of the USB driver a COM port number will be assigned to the VCP (open the Device Manager to figure out). After starting CTconnect please enter the correct COM port number in the menu item **Setup/ Interface**.

Operation

The programming keys **Mode**, **Up** and **Down** enable the user to set the sensor on-site. The current measuring value or the chosen feature is displayed. With **Mode** the operator obtains the chosen feature, with **Up** and **Down** the functional parameters can be selected. If no key is pressed for more than 10 seconds the display automatically shows the calculated object temperature (according to the signal processing).

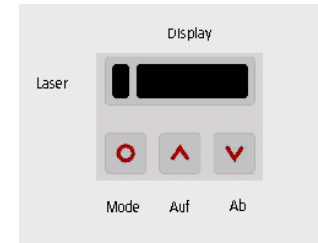

Pressing the **Mode** button again recalls the last called function on the display.
The signal processing features **Peak hold** and **Valley hold** cannot be selected simultaneously.

► **More information in chapter 5**

Factory default setting

To set the PCE-IR10 back to the factory default settings, please press at first the **Down**-key and then the **Mode**-key and keep both pressed for approx. 3 seconds.

The display shows **RESET** for confirmation.

Error messages

The display of the PCE-IR10 can show the following error messages:

- **OVER** temperature overflow
- **UNDER** temperature underflow
- **^^^CH** head temperature to high
- **vvvCH** head temperature to low

2 Technical Data

2.1 General Specifications

	Sensing head	Electronic box
Environmental rating	IP65 (NEMA-4)	IP65 (NEMA-4)
Ambient temperature	-20 – 180 °C (20:1/ 15:1 head) -20 – 130 °C (2:1 head)	0 – 65 °C
Storage temperature	-40 – 180 °C (20:1/ 15:1 head) -40 – 130 °C (2:1 head)	-40 – 85 °C
Relative humidity	10 – 95 %, non condensing	10 – 95 %, non condensing
Material	stainless steel	die casting zinc
Dimensions	28 mm x 14 mm	89 mm x 70 mm x 30 mm
Weight	40 g	420 g
Vibration	IEC 68-2-6: any axis, 11 – 200 Hz, 3G	
Shock	IEC 68-2-27: any axis, 11 ms, 50G	
Cable length	1 m (Standard), 3 m, 8 m, 15 m	
Cable diameter	2,8 mm	

2.2 Electrical Specifications

Power supply	8 VDC – 36 VDC
Current draw	max. 100 mA
Outputs/ analog	
Channel 1 (Object temperature)	0 – 20 mA or 4 – 20 mA or 0 – 5 V or 0 – 10 V or thermocouple type J or K
Channel 2 (Head temperature)	0 – 5 V or 0 – 10 V; 10 mV/ K or alarm output
Relais	2 x 60 VDC/ 42 VAC _{RMS} , 0,4 A; optically isolated (optional module)
Output impedances	
mA	max. loop resistance 500 Ω (at 8 -36 VDC),
mV	min. 100 K Ω load impedance
Thermocouple	20 Ω
Functional inputs	F1 – F3; software programmable for the following functions: - external emissivity adjustment, - ambient temperature compensation, - trigger (reset of hold functions)
Digital interface	USB, RS232, RS485 (optional modules)

2.3 Measurement Specifications

	Sensing head 20:1	Sensing head 15:1	Sensing head 2:1
Spectral range	8 – 14 μm	8 – 14 μm	8 – 14 μm
Temperature range	-40 – 900 °C	-40 – 600 °C	-40 – 600 °C
Optical resolution	20:1	15:1	2:1
Response time	150 ms (95 %)	150 ms (95 %)	150 ms (95 %)
System accuracy ^{1), 2)}	$\pm 1 \%$ or $\pm 1 \text{ }^\circ\text{C}$	$\pm 1 \%$ or $\pm 1 \text{ }^\circ\text{C}$	$\pm 1 \%$ or $\pm 1 \text{ }^\circ\text{C}$
Repeatability ¹⁾	$\pm 0,5 \%$ or $\pm 0,5 \text{ }^\circ\text{C}$	$\pm 0,5 \%$ or $\pm 0,5 \text{ }^\circ\text{C}$	$\pm 0,5 \%$ or $\pm 0,5 \text{ }^\circ\text{C}$
Temperature resolution ³⁾	0,1 °C	0,1 °C	0,1 °C
Temperature Coefficient ^{1), 4)}	$\pm 0,05 \%$ / K or $\pm 0,05 \text{ K/ K}$	$\pm 0,05 \%$ / K or $\pm 0,05 \text{ K/ K}$	$\pm 0,05 \%$ / K or $\pm 0,05 \text{ K/ K}$
Signal processing	peak hold, valley hold, average		
Emissivity	0,100 – 1,100 (manual or digital adjustable)		
Transmission	0,100 – 1,100 (manual or digital adjustable)		

¹⁾ whichever is greater

²⁾ T > -20 °C; ambient temperature 23 °C \pm 5 °C

³⁾ at a temperature span of 300 °C, e.g. temperature range 0 °C – 300 °C

⁴⁾ at head temperature 0 – 180 °C (0 – 130 °C at 2:1)

2.4 Optical Charts

The following optical charts show the diameter of the measuring spot in dependence on the distance between measuring object and sensing head. The spot size refers to 90 % of the radiation energy.

The size of the measuring object and the optical resolution of the infrared thermometer determine the maximum distance between sensing head and measuring object. In order to prevent measuring errors the object should fill out the field of view of the optics completely. Consequently, the **spot** should at all times have at least the **same size** like the object or should be **smaller** than that.

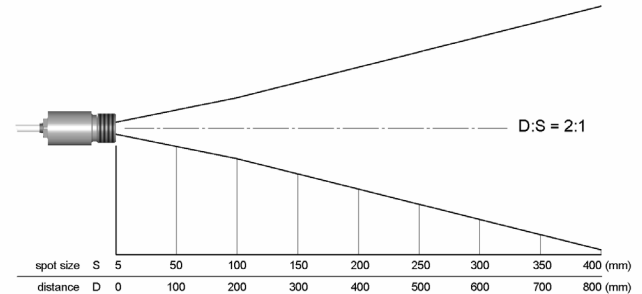
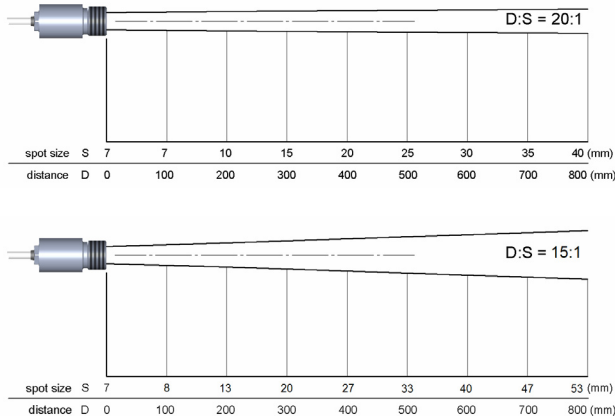

Fig. 2-1: Optical charts sensing head 20:1, 15:1 and 2:1

2.5 CF-Optics

The optional CF-lens allows the measurement of small objects. The minimum spot size depends on the used sensing head:

- 2:1** 2,5 mm@ 23 mm
2,5 mm@ 21 mm with laminar air purge¹⁾
- 15:1** 0,8 mm@ 10 mm
0,8 mm@ 8 mm with laminar air purge¹⁾
- 20:1** 0,6 mm@ 10 mm
0,6 mm@ 8 mm with laminar air purge¹⁾

¹⁾ measured from front edge of the laminar air purge

If the CF-lens is used, the transmission has to be set to 0,78 (see chapter 5 and 6.4.1).

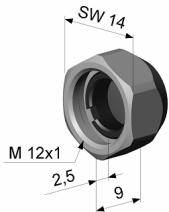

Fig. 2-2: CF-lens

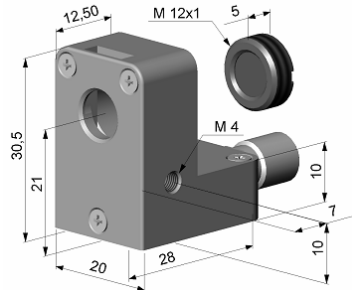

Fig. 2-3: laminar air purge with integrated CF-lens

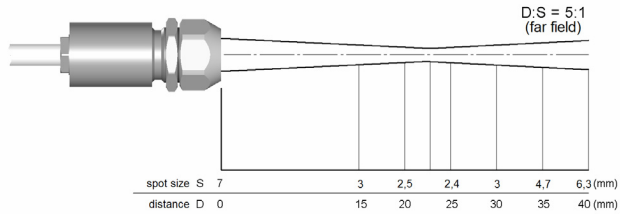

Fig. 2-4: 2:1-head with CF-lens

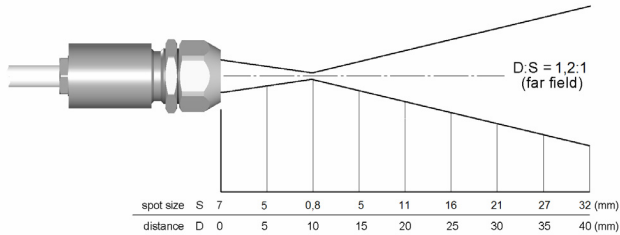

Fig. 2-5: 15:1-head with CF-lens

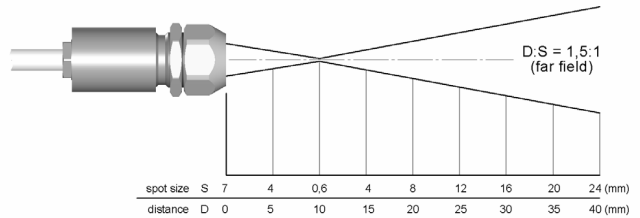

Fig. 2-6: 20:1-head with CF-lens

3 Mechanical Installation

PCE-IR10 heads are equipped with a metrical M12x1-thread and can be installed either directly via the sensor thread or with the help of the hex nut (delivered as standard) to the mounting bracket available. Various mounting brackets, which make the adjustment of the sensing head easier, can be additionally ordered as accessories.

Make sure to keep the optical path clear of any obstacles (see chapter 2.4).

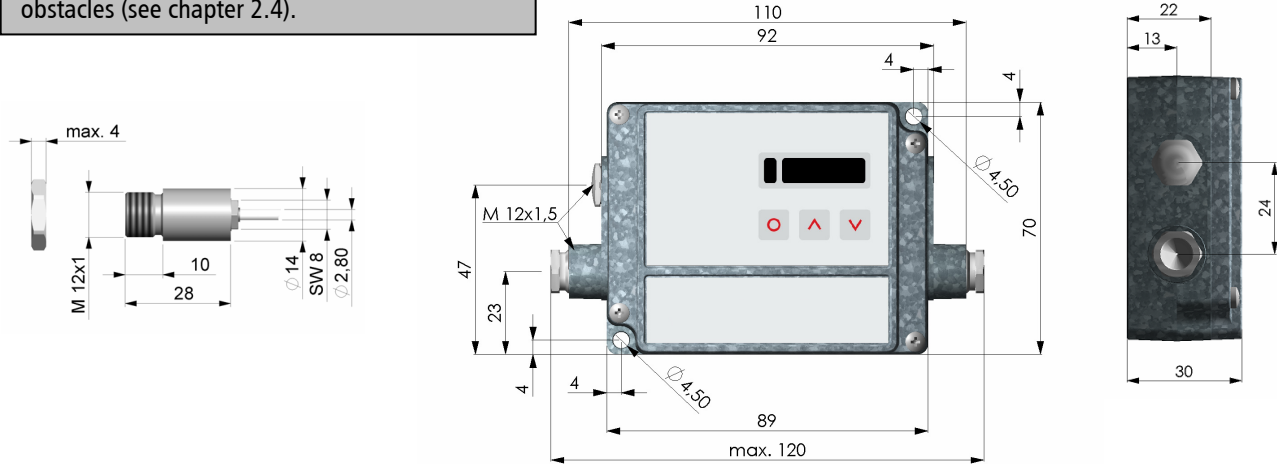
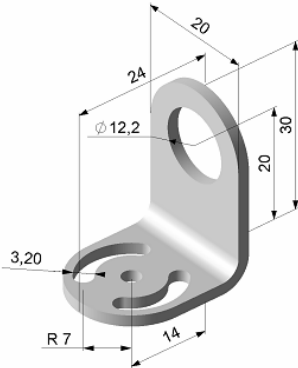

Fig. 3-1: Dimensions PCE-IR10 head and electronic box

A combination of mounting bracket and bolt forms a mounting bracket, which is adjustable in two axes.



Mounting bracket, adjustable in one axes

The mounting fork can be combined with the mounting bracket with the M12x1-thread.

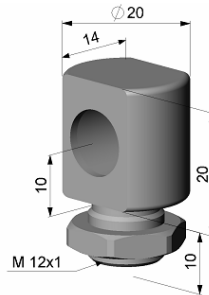

Mounting bolt with M12x1 thread, adjustable in one axes

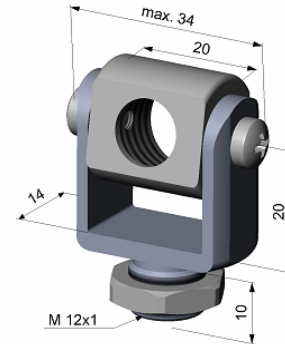

Mounting fork with thread M 12x1, adjustable in 2 axes

Fig. 3-2: Mounting Brackets

The lens must be kept clean at all times from dust, smoke, fumes and other contaminants in order to avoid reading errors. These effects can be reduced by using an air purge collar. Make sure to use oil-free, technically clean air, only.

The PCE-IR10-high-temperature sensing heads are designed to measure temperatures while tolerating ambient temperatures ranging between **0 and 180 °C** (20:1/ 15:1 head) or **0 and 130 °C** (2:1 head). The cable between head and electronics is teflon coated and also usable for this ambient temperature range. Therefore measurements in the specified range can be done without a cooling of the sensing head.

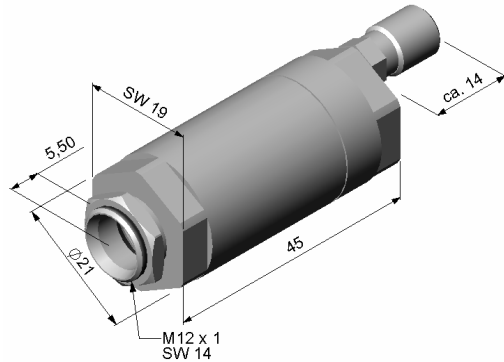

Standard air purge collar, may be combined with mounting bracket; hose connection: 3x5 mm

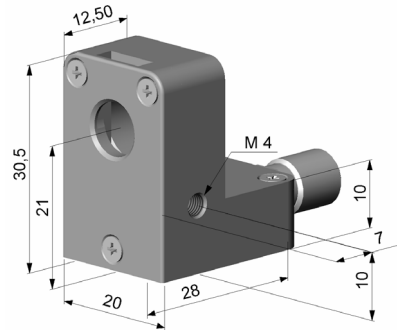

Laminar air purge collar – the side air outlet prevents a cooling down of the object in short distances; hose connection: 3x5 mm

The needed amount of air (approx. 2...10 l/ min.) depends on the application and the installation conditions on-site.

A combination of the laminar air purge collar with the bottom section of the mounting fork forms a unit, which is adjustable in two axes.

Fig. 3-3: Air purge collars

4 Electrical Installation

4.1 Cable Connections

For the electrical installation please open at first the cover of the PCE-IR10 electronic box (4 screws). Below the display are the screw terminals for the cable connection.

Designation:

+8 ... 36VDC	Power supply
GND	Ground (0V) of power supply
GND	Ground (0V) of internal in- and outputs
OUT-AMB	Analog output head temperature (mV)
OUT-TC	Analog output thermocouple (J or K)
OUT-mV/mA	Analog output object temperature (mV or mA)
F1-F3	Functional inputs
PINK	Power supply laser (+)
GRAY	Power supply laser (-)
BROWN	Temperature probe head
WHITE	Temperature probe head
GREEN	Detector signal (-)
YELLOW	Detector signal (+)

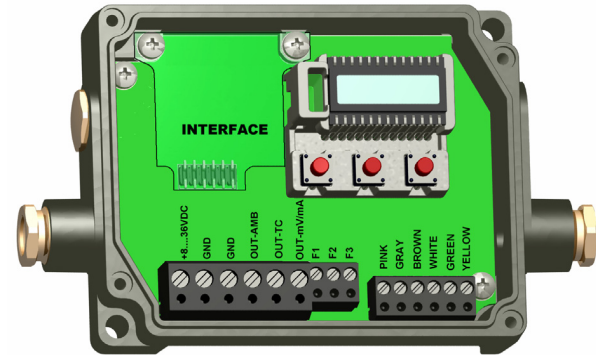

Fig. 4-1: Open PCE-IR10 electronic box with screw terminals

Power supply:

Please use a power supply unit with an output voltage of 8 – 36 VDC/ 100 mA.

Cable assembling:

The cable gland M12x1,5 allows the use of cables with a diameter of 3 to 5 mm.

Remove the isolation from the cable (40 mm power supply, 50 mm signal outputs, 60 mm functional inputs). Cut the shield down to approximately 5 mm and spread the strands out. Extract about 4 mm of the wire isolation and tin the wire ends.

Place the pressing screw, the rubber washer and the metal washers of the cable gland one after the other (according Fig. 4-2) onto the prepared cable end. Spread the strands and fix the shield between two of the metal washers. Insert the cable into the cable gland until the limit stop. Screw the cap tight.

Every single wire may be connected to the according screw clamps according to their colors.

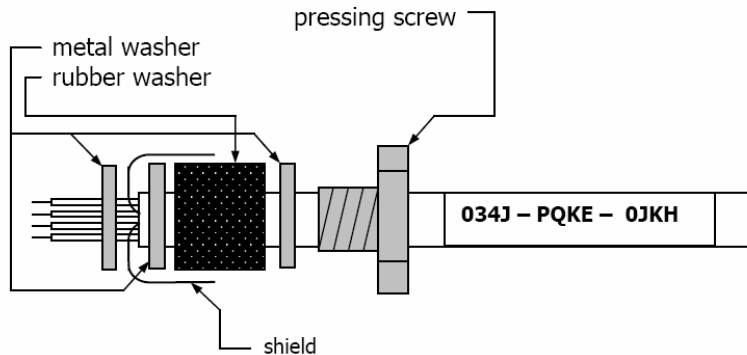

Use shielded cables only. The sensor shield has to be grounded.

Fig. 4-2: Cable assembling

4.2 Exchange of the Sensing Head

The standard delivery includes the connected cable of the sensing head to the electronic box. You may shorten but never lengthen the cable. To shorten the cable may cause additional measuring errors of about **0,1 K/ m**. The head is exchangeable.

After exchanging a head the calibration code of the new head must be entered into the electronics.

Entering the calibration code:

Sensing heads of the PCE-IR10 series are exchangeable. Every head has a specific **calibration code**, which is printed on the head cable. For a correct temperature measurement and functionality of the PCE-IR10 this calibration data must be stored in the electronic box. The calibration code consists of **three blocks** with **4 characters** each.

Example: **EKJO – OAUD – OA1B**
 block 1 block 2 block 3

For entering the code please press the **Up**- and **Down**-key (keep pressed) and *then* the **Mode**-key.

The display shows **HCODE** and then the 4 signs of the first block. With **Up** and **Down** each sign can be changed, **Mode** switches to the next sign or next block.



You will find the calibration code on a label fixed on the head cable (near the electronic box). If you shorten the cable, please make sure to note the calibration code. The code is needed if the head will be changed.

4.3 Outputs

The PCE-IR10 has two output channels. **Output channel 1** is used for the object temperature. The CTconnect software allows the programming of this output as an alarm output.

Output	Range	Connection-Pin on PCE-IR10-Board
Voltage	0 ... 5 V	OUT-mV/mA
Voltage	0 ... 10 V	OUT-mV/mA
Current	0 ... 20 mA	OUT-mV/mA
Current	4 ... 20 mA	OUT-mV/mA
Thermocouple	TC J	OUT-TC
Thermocouple	TC K	OUT-TC

According to the chosen output signal there are different connection pins on the PCE-IR10 board (**OUT-mV/mA** or **OUT-TC**).

Tab. 4-1: Analog outputs

Output channel 2 (connection pin **OUT AMB**) is used for the head temperature (-20 – 180 °C as 0 – 5 V or 0 – 10 V) or as alarm output. Activating this channel as alarm output requires the CTconnect software. Additionally to the head temperature also the object or electronic box temperature can be selected as alarm source.

4.3 Digital Interfaces

PCE-IR10 sensors are optionally equipped with an USB-, RS232-, RS485- or relais-interface.

If you want to install an interface, plug the interface board into the place provided, which is located beside the display (see Fig. 4-1). In the correct position the holes of the interface match with the thread holes of the electronic box. Now press the board down to connect it with the PCE-IR10 and use both M3x5 screws for fixing it. Plug the preassembled interface cable with the terminal block into the male connector of the interface board. In case you want to use the delivered cable gland M12x1,5 for the preassembled cable, the terminal block has to be disassembled/ assembled. Make sure the wiring is correct (Fig. 4-3).

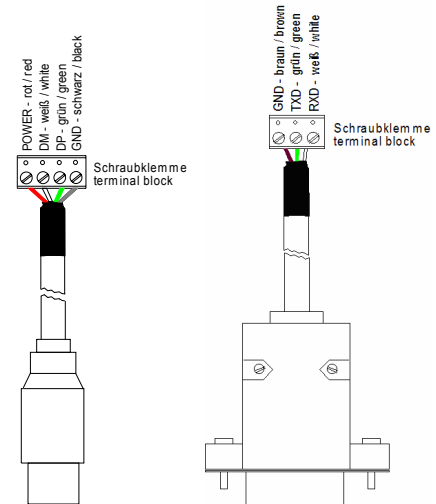

Fig. 4-3: Interface cables: USB (left), RS232 (right)

USB-interface:

If you use the USB-interface, the PCE-IR10 needs no external power supply for operation – it will be powered by the USB-interface. If an external power supply has already been installed, this will have no effect on the functionality of the PCE-IR10. After the interface board has been installed and the USB-cable has been connected to your PC, please install the USB driver as described in

chapter 6.1. After this you can start the CTconnect software and the communication will be established.

RS232-interface:

If the RS232-interface is used, the PCE-IR10 unit in any case needs an external power supply for operation. After the interface board has been installed and the RS232-cable has been connected to your PC, the communication will be established.

Relais-interface:

After installing the interface board as described above please connect the electrical circuit with the terminal block. A red LED shows the closed current switch. The relais board provides two fully isolated switches, which have the capability to switch max. 60 VDC/ 42 VAC^{RMS}, 0,4 A DC/AC.

The factory default settings for the switching thresholds (alarm values) are: **Alarm 1 = 30 °C/ norm. closed (low alarm)** and **Alarm 2 = 100 °C/ norm. open (high alarm)**. To make advanced settings (change of low- and high alarm) a digital interface (USB, RS232) and the software CTconnect is needed.

RS485-interface:

Please install the interface board as described above and connect the RS485-USB-adapter via the supplied USB cable with your computer. After it has been connected the computer will recognize a new USB-device and (if connected the first time) will ask for installation of the according driver software. Select **Search** and install the RS485-adapter USB-driver from the software CD. The RS485-USB-adapter provides a 2-wire half-duplex mode. Please connect terminal A of the adapter with terminal A of the RS485-interface of the first PCE-IR10 and from there to terminal A of the next PCE-IR10 and so on. With the B terminals proceed as well.

Make sure, that you always connect A to A and B to B, not reverse. You may run up to 32 PCE-IR10 units on one RS485-USB-adapter. The 120R-switch is to be turned to **ON** at one of the connected PCE-IR10 units, only. Each PCE-IR10 unit connected to the RS485 needs a different multidrop address between 1 and 32 (see chapter 6.4.3).

Independent from the used interface the setting for baud rate in the software must be the same as on the PCE-IR10 unit (factory default: 9,6 kBaud).

4.5 Functional Inputs

The three functional inputs F1 – F3 can be programmed with the CTconnect software, only.

- F1 (digital): trigger (a 0 V level on F1 resets the hold functions)
- F2 (analogue): external emissivity adjustment (0 – 10 V: 0 V → $\varepsilon=0,1$; 9 V → $\varepsilon=1$; 10 V → $\varepsilon=1,1$)
- F3 (analogue): external compensation of ambient temperature (0 – 10 V → -40 – 900 °C; the range is scalable via CTconnect software/ preset range: -20 – 200 °C)
- F1 – F3 (digital): emissivity (digital choice via table, non-connected input represents high-level)
 - high-level: $\geq +3 \text{ V} \dots +36 \text{ V}$
 - low-level: $\leq +0,4 \text{ V} \dots -36 \text{ V}$

5 Operation

The programming keys **Mode**, **Up** and **Down** enable the user to set the sensor on-site. The current measuring value or the chosen feature is displayed. With **Mode** the operator obtains the chosen feature, with **Up** and **Down** the functional parameters can be selected. If no key is pressed for more than 10 seconds the display automatically shows the calculated object temperature (according to the signal processing).

Factory default settings:

Signal output object temperature	0 – 5 V
Emissivity	0,970
Transmissivity	1,000
Average time	0,2 s
Peak hold	inactive
Valley hold	inactive
Lower limit temperature range	0 °C
Upper limit temperature range	500 °C
Lower limit signal output	0 V
Upper limit signal output	5 V
Temperature unit	°C
Lower alarm limit	30 °C (norm. closed)
Upper alarm limit	100 °C (norm. open)
Ambient temperature compensation	head temperature (0-5 V/ -20 – 180 °C)
Baud rate	9,6 kBaud

Pressing the Mode button again recalls the last called function on the display.
The signal processing features **Peak hold** and **Valley hold** cannot be selected simultaneously.

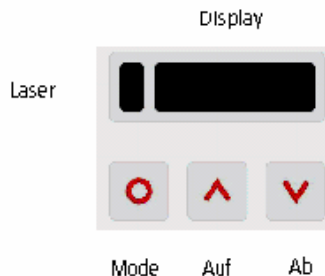

Fig. 5-1: Display and programming keys

Display	Mode [Sample]	Adjustment Range
142.3C	Object temperature (after signal processing) [142,3 °C]	fixed
127CH	Head temperature [127 °C]	fixed
25CB	Box temperature [25 °C]	fixed
142CA	Current object temperature [142 °C]	fixed
□0-20	Signal output channel 1 [0 - 20 mA]	<input type="checkbox"/> 0-20 0 – 20 mA Current loop <input type="checkbox"/> 4-20 4 – 20 mA Current loop <input type="checkbox"/> MV5 0 – 5 V Voltage output <input type="checkbox"/> MV10 0 – 10 V Voltage output <input type="checkbox"/> TCJ Thermocouple type J <input type="checkbox"/> TCK Thermo couple type K
E0.970	Emissivity [0,970]	0,100 ... 1,100
T1.000	Transmissivity [1,000]	0,100 ... 1,100
A 0.2	Signal output average [0,2 s]	A---- = inactive/ 0,1 ... 999,9 s
P----	Signal output peak hold [inactive]	P---- = inactive/ 0,1 ... 999,9 s/ P_{∞} = infinite
V----	Signal output valley hold [inactive]	V---- = inactive/ 0,1 ... 999,9 s/ V_{∞} = infinite
u .0	Lower limit temperature range [0 °C]	-40,0 ... 900,0 °C/ inactive at TCJ- and TCK-output
n500.0	Upper limit temperature range [500 °C]	-40,0 ... 900,0 °C/ inactive at TCJ- and TCK-output
[0.00	Lower limit signal output [0 mA]	according to the range of the selected output signal
]20.00	Upper limit signal output [20 mA]	according to the range of the selected output signal
U °C	Temperature unit [°C]	°C/ °F
-40.0	Lower alarm limit [-40 °C]	-40,0 ... 900,0 °C
900.0	Upper alarm limit [900 °C]	-40,0 ... 900,0 °C
XHEAD	Ambient temperature compensation [head temperature]	XHEAD = head temperature/ -40 – 900 °C as fixed value for compensation/ returning to XHEAD (head temperature) by pressing Up and Down together
M 01	Multidrop address [1] (only with RS485 Interface)	01 ... 32
B 9.6	Baud rate = 9,6 kBaud	9,6/ 19,2/ 38,4/ 57,6/ 115,2 kBaud

Tab. 5-1: Adjustment modes

Factory default setting:

To set the PCE-IR10 back to the factory default settings, please press at first the **Down**-key and then the **Mode**-key and keep both pressed for approx. 3 seconds.

The display shows **RESET** for confirmation.

Error messages:

The display of the PCE-IR10 can show the following error messages:

- **OVER** temperature overflow
- **UNDER** temperature underflow
- **^^^CH** head temperature to high
- **vvvCH** head temperature to low

6 Software CTconnect

6.1 Installation

Features:

- configure PCE-IR10 sensors
- setup parameters and adjust the sensor to your application
- display and record temperature trends

System requirements:

- Windows XP, 2000
- RS232 or USB interface (depends on the interface board plugged in the PCE-IR10)
- Hard disk with at least 30 MByte free space
- At least 128 MByte RAM
- CD-ROM-drive

Insert the CTconnect Installation CD.

If the auto run option on your computer is activated the installation wizard will start automatically. Otherwise please start **setup.exe** on the CD-ROM. Follow the instructions of the wizard until the installation is finished.

If you want to uninstall the software from your system please use the **uninstall** icon in the start menu.

USB driver:

To use the PCE-IR10 unit with USB interface please connect the sensor via the supplied USB connection cable with a free USB slot of your computer. The operating system will auto detect the new hardware and open a wizard. Chose the **automatic installation** and follow the instructions. The drivers will be copied to your computer.

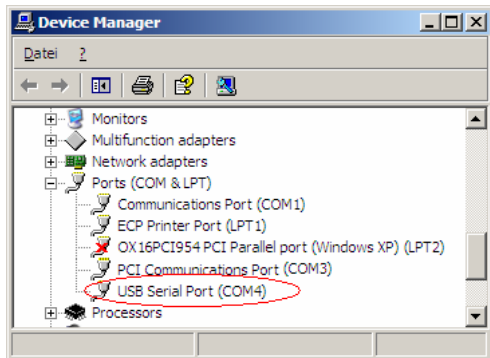

If you use the USB-interface board or the RS232-interface board and your own RS232-to-USB-adaptor you will see the COM port as a **virtual COM port (VCP)** in your system. During the installation of the USB driver a COM port number will be assigned to the VCP (open the Device Manager to figure out). After starting CTconnect please enter the correct COM port number in the menu item **Setup/ Interface**.

Fig. 6-1: COM-Port number in Device manager window

6.2 Starting the Software

Please connect your PCE-IR10 with the USB cable to a free USB port or with the serial cable (9-pin-plug) to a free RS232 port (choose the connection according to the plugged interface board).

Launch the CTconnect software.

The default setting for the communication is: **COM1 with 9600 baud**.

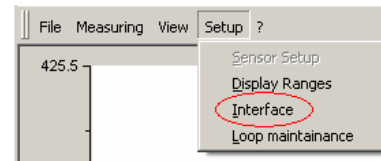

The setting for baud rate in the software must be the same as on the PCE-IR10 unit (factory default: 9,6 kBaud).

If you use the PCE-IR10 on a different port or with a different baud rate you have to change the interface settings under **Setup/ Interface**.

Address mode:

- no address:** Single sensor operation via USB/ RS232
- auto scan:** automatic address search (RS485 operation)
- fixed address:** input of a known address

Deactivating **Checksum** 's allows compatibility to older PCE-IR10 sensors (presetting: activated).

Connection state: In the lower left corner the current connection state will be displayed:

- Online:** Application is properly connected with the PCE-IR10/ normal data exchange
- Offline:** No connection to the PCE-IR10/ no data exchange
- Connecting:** Connection to a PCE-IR10 unit will be established
- Addr. xx:** only during network operation (RS485): shows the current PCE-IR10 address

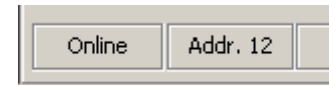
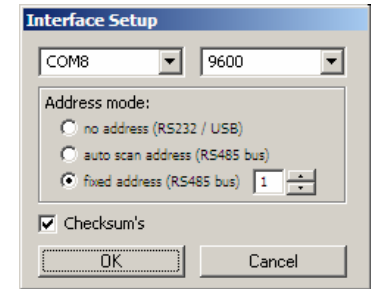

6.3 Diagram Functions

The diagram will be started by pressing the Start button or by opening a stored data file. In any case the graph shows the object temperature.

Temperature displays:

TObj: The big display and the assigned temperature bar show the object temperature. If no measuring is started this temperature will be actualized every **200 ms** (after starting the measurement: every **20 ms**).

TBox: Display and temperature bar show the temperature of the electronic box

THead: Display and temperature bar show the temperature of the PCE-IR10 head The values for **TBox** and **THead** will be actualized every second.

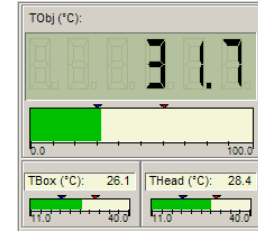

Fig. 6-2: Temperature displays

Temperature bars:

The temperature values on the left and on the right side indicate the range of the bar graph. Above the bar you will find two markers for low alarm and high alarm. If low alarm is active the color of the bar will change from green to blue, if high alarm is active from green to red.

Both alarms have nothing to do with the alarm values from the PCE-IR10 unit. A hysteresis of 2 K is set fixed on both alarms.

The values for temperature range and alarm can be set in the menu item **Setup/ Display Ranges**.

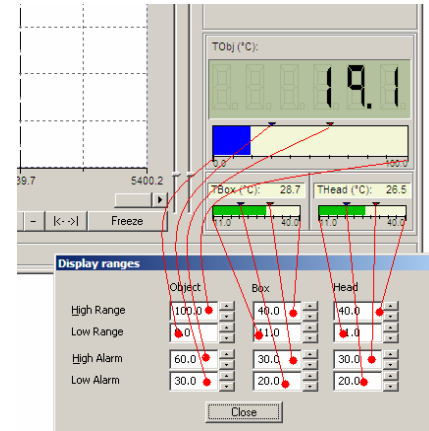

Fig. 6-3: Temperature bar graphs and display ranges

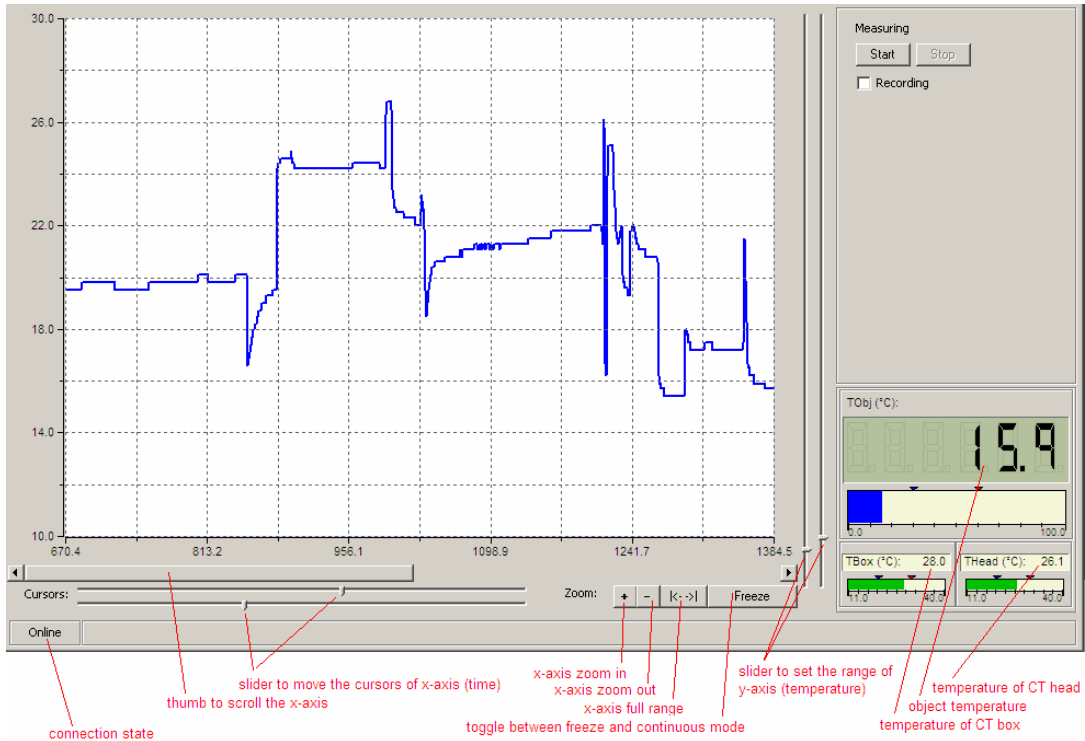
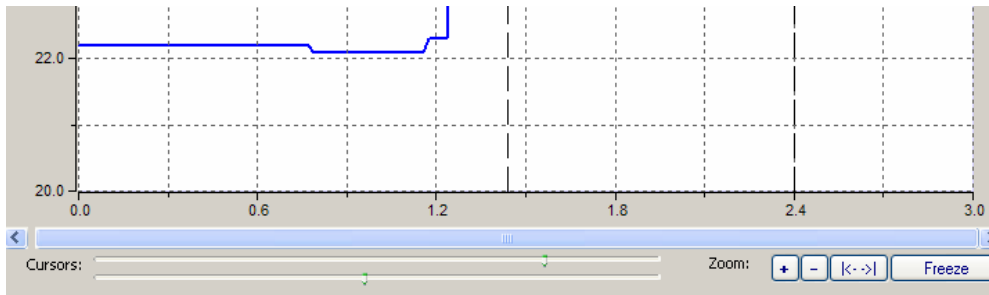

Fig. 6-4: Displays and setting features of the software

Time axis:

To zoom the x-axis set the cursors according to the time range you are interested in. Use both sliders under the diagram. After you pushed the Zoom-in button **+** the marked range will expand to full size. With the Zoom-out button **-** you will reach the opposite effect. With the scroller of the x-axis you can move through the time range of the diagram. The full range button **|<->|** helps you to zoom-out of the diagram to the full range of the available data.



The temperature values in the diagram will be updated every **20 ms**.

Fig. 6-5: Time axis below the diagram

Freeze and Continue:

Any action with the time axis will set the diagram into the **Freeze** modus. If you want to continue with the live data please press the button **Continue**. The button changes its function between **Freeze** and **Continue**. Stopping the diagram with the **Freeze** button will only stop the updating. The application proceeds with data collecting in the background. To stop the measurement you have to press the button **Stop**.

Temperature axis:

The range adjustment of the y-axis depends on the selected scaling settings under View/ Settings. Only if **Manual scaling** is activated, both sliders are enabled to set the upper and lower temperature range of the diagram (Fig. 7-4). Both y-sliders are of equal rank. The prevailing higher slider represents the high range of the diagram and vice versa.

Recording and play-back of data:

To record temperature data, please activate the **Recording** checkbox. Under **Recording Interval** you can define the time interval of the recorded values (shortest time: **20 ms**).

After the **Start** button was pressed the application will record the temperatures (TObj, TBox and THead) to an appropriate data file. After you stopped the measuring the program will ask you for a path and filename to store the file. The stored data file (*.dat) is readable with any text editor and can easily be imported into MS Excel. To play back the recorded data open the data file with the menu item **File/ Open**. To zoom the x- and y-axis proceed in the same way like with live data.

Example:

```
[CT-Connect DataFile][1.0]
Date:      08.04.2004
Time:      10:18:13.879
Unit:      °C
```

Time	TObj	TBox	THead
00:00:00.020	19.9	28.4	26.7
00:00:00.040	20.1	28.4	26.7
00:00:00.060	19.8	28.4	26.7
00:00:00.080	19.8	28.4	26.7
00:00:00.100	19.9	28.4	26.7
00:00:00.120	19.7	28.4	26.7
00:00:00.140	19.8	28.4	26.7

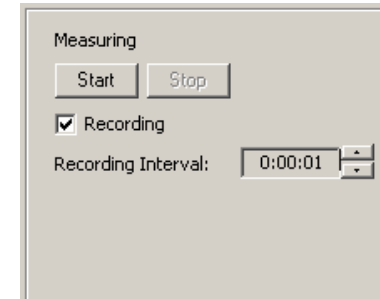

Scaling settings:

The scaling of the diagram can be set with the menu item **View/ Settings**. This menu item will open the following dialog:

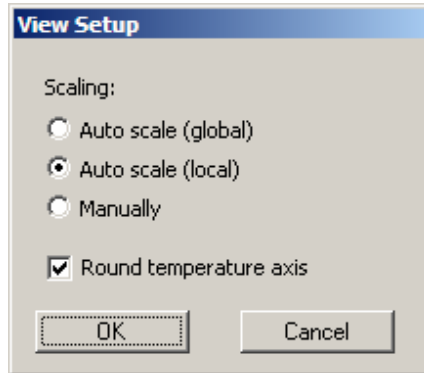

For the scaling of the y-axis three alternatives are available:

- **Auto-Scale (global):** If a value exceeds the shown diagram range, the range will be extended to fit the diagram curve. The range will not be reduced again. The sliders on the right side of the diagram are inactivated.
- **Auto-Scale (local):** If a value exceeds the shown diagram range, the range will be extended to fit the diagram curve. The range will be reduced again if the peak value is not displayed in the diagram anymore. This option ensures the best fitting of the curve to the diagram but it can cause flickering if the signal is noisy. The sliders on the right side of the diagram are inactivated.
- **Manually:** If this option is active the scaling can be performed by hand using the sliders on the right-hand side of the diagram.

To prevent odd values on the temperature axis (y-axis) check the option **Round temperature axis**.

6.4 Configuration of the PCE-IR10

An essential part of the software is the parameterization of the PCE-IR10. For this purpose use the menu item **Setup/Sensor**. In the top line you will find the serial-number of the connected PCE-IR10 and the firmware revision.

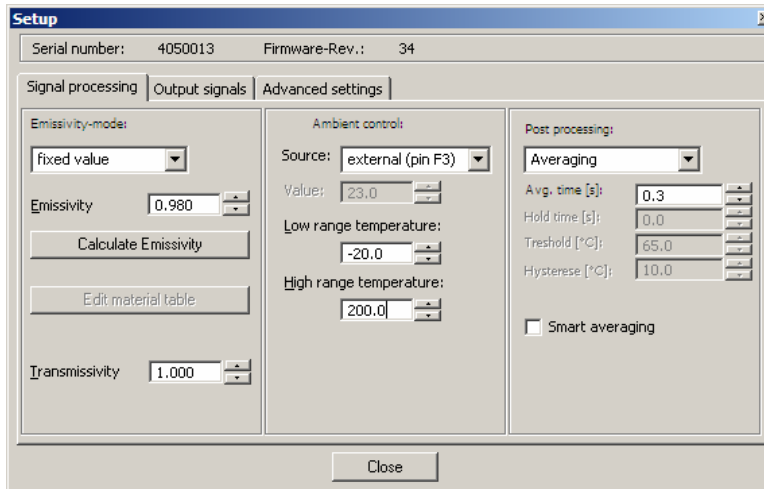

Most of the parameters have an immense effect on the signal output and functionality of the sensor. Please double-check that the settings you carried out match with your aims.

Fig. 6-6: Setup dialog – window *Signal Processing*

The setup dialog consists of three parts:

- **Signal processing:** emissivity and transmissivity control, ambient control, post processing
- **Output signals :** output channels and alarm settings
- **Advanced settings:** head parameters, device adjustment, multidrop address

6.4.1 Signal Processing

If the setup dialog is open, the following parameters can be adjusted (part **Signal processing**):

Emissivity adjustment:

There are three options to set the emissivity:

Fixed value: The value can be set by the edit box **Emissivity**.

External: The value is determined by a voltage on the functional input pin F2.
(0–10 V: 0 V → $\varepsilon=0,1$ / 9 V → $\varepsilon=1,0$ / 10 V → $\varepsilon=1,1$)

Table: Input of up to eight emissivity values and corresponding alarm values (two for each emissivity value) in a **material table**. The selection of the tabular values occurs by a combination of low- and high-levels on the functional inputs F1 to F3 (non-connected input represents high-level).
high-level: $\geq +3 \text{ V} \dots +36 \text{ V}$
low-level: $\leq +0,4 \text{ V} \dots -36 \text{ V}$

Table entry	F1	F2	F3
0	0	0	0
1	0	0	1
2	0	1	0
3	0	1	1
4	1	0	0
5	1	0	1
6	1	1	0
7	1	1	1

Editing the material table:

Pushing the button **Edit material table** calls the material table dialog:

	Eps.	Alarm A	Alarm B
0	0.100	1.0	11.0
1	0.201	2.0	22.0
2	0.302	3.0	33.0
3	0.403	4.0	44.0
4	0.504	5.0	55.0
5	0.650	6.0	66.0
6	0.750	7.0	77.0
7	1.099	8.0	88.0

Alarm output to:

not specified

output channel 1

output channel 2

alarm 1 (blue)

alarm 2 (red)

OK Cancel

An emissivity value and two alarm values can be set for each entry. Both alarms A and B are logical entities and must be assigned to one of four possible alarm channels concerning the following criteria:

If you do not want to use an alarm with the table please activate **not specified**.

Only one alarm (A or B) can be assigned to each alarm channel.

An assigned alarm value overwrites the alarm value setting of the appropriate alarm on the **Output signals** tab.

Other properties like **normally open/close**, **alarm source** must be defined on the **Output signals** tab.

Output channel 1 and 2 are only useable in this table if they are configured as digital on the **Output signals** tab.

Emissivity calculation:

If the current object temperature is the only value known to you, you may determine the emissivity as follows:

Set the **Emissivity mode** to **Fixed Value** and press the button **Calculate Emissivity**:

Type the known object temperature in the edit box **Required temperature**. Press the button **Acquire data and calculate emissivity**.

The field **Current Temperature** should display the object temperature and the field **Emissivity** the calculated emissivity. Press the **OK** button – the window will be closed and the emissivity value transferred.

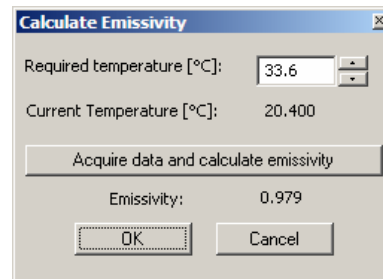

Transmissivity adjustment:

In this edit box you can enter a value for transmissivity (e.g. if a protective window is used or if the CF-lens is mounted).

Ambient temperature compensation:

In dependence on the emissivity value a certain amount of ambient radiation will be reflected from the object surface. To compensate this impact, the CT Connect software provides the feature **Ambient control** (middle of the window **Signal processing**):

- **internal (Head):** The ambient temperature will be taken from the head-internal Pt1000 probe (factory default setting).
- **external:** The ambient temperature will be determined by a voltage on the functional input-pin F3 (0 – 10 –40 – 900 °C; range scalable). With an external probe or with a second PCE-IR10 a real-time ambient temperature compensation can be realized.
- **fixed value:** In the edit box **Value** a fixed value can be entered (if the ambient radiation is constant).

Especially if there is a big difference between object and head temperature the use of Ambient control with **external input** or **fixed value** is recommended.

Post processing:

The post processing supplies some functions to process data after the basic temperature calculation. The following table shows these functions:

Modus	Average Time	Hold Time	Threshold	Hysteresis
Off				
Averaging	X			
Peak hold	X	X		
Valley hold	X	X		
Advanced peak hold	X		X	X
Advanced valley hold	X		X	X

Tab. 6-1: Post processing modes and the used parameters

With the menu item **Measuring/ Signal Processing Monitor** you can open a utility to monitor the behavior of the signal post processing. It always shows the **Current Temperature** (w/o post processing) and the **Process Temperature** (with post processing) as a value and as a graph. The temperature range is adjustable with the sliders.

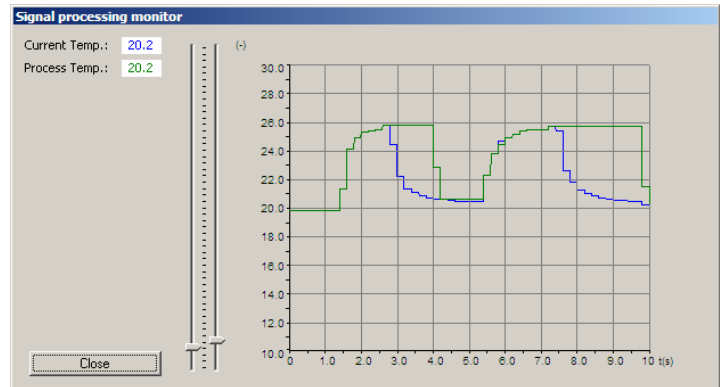

If the post processing mode is **Off** no post processing will be done.

Averaging:

In the mode **Averaging** a plain arithmetic algorithm will be performed to smoothen the signal. The **Avg. time** is the time constant. This function can be combined with all other post processing functions.

Peak hold:

In the mode **Peak hold** the PCE-IR10 unit is waiting for descending signals. If the signal descends the algorithm maintains the previous signal peak for the specified hold time.

- Signal with Post processing
- Object temperature (without Post processing)

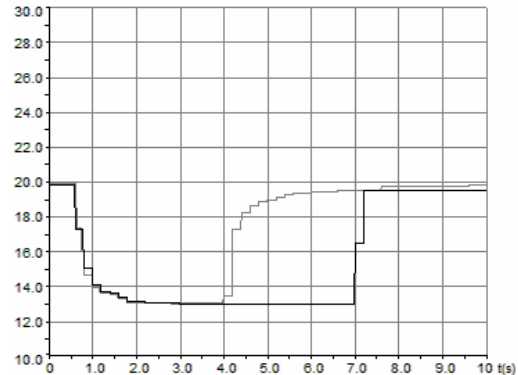
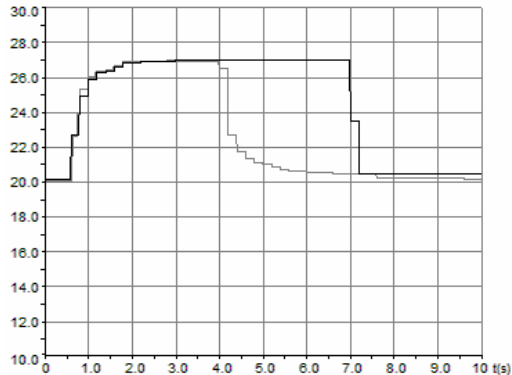

Fig. 6-7: Signal graph with Peak hold (left) and Valley hold (right)/ Hold time = 3 s

Valley hold:

In the mode **Valley Hold** the PCE-IR10 unit waits for ascending signals. If the signal ascends the algorithm maintains the previous signal valley (minimum) for the specified hold time.

Advanced Peak hold:

In the mode **Advanced Peak Hold** the PCE-IR10 unit waits for local peak values. The signal must drop below the **Threshold** value to detect the next peak (which must be \geq threshold). Furthermore, the **Hysteresis** causes to only accept a new peak, if the signal descends by the value of the hysteresis.

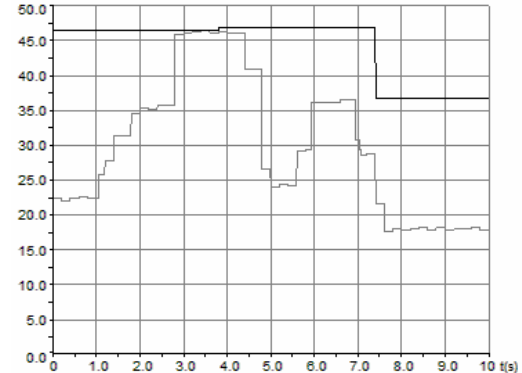
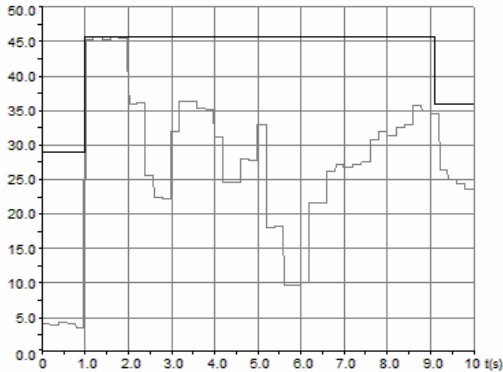

Fig. 6-8: Signal graph with Advanced Peak hold: Threshold = 20 °C (left)/ Threshold = 25 °C and Hysteresis = 12 °C (right)

Advanced Valley hold:

The mode **Advanced Valley hold** is the inverted function of **Advanced Peak hold**. The PCE-IR10 unit waits for local minima. The signal must exceed the **Threshold** value to detect the next valley (which must be \leq threshold). Furthermore, the **Hysteresis** causes to only accept a new valley, if the signal ascends by the value of the hysteresis (Fig. 6-9 right).

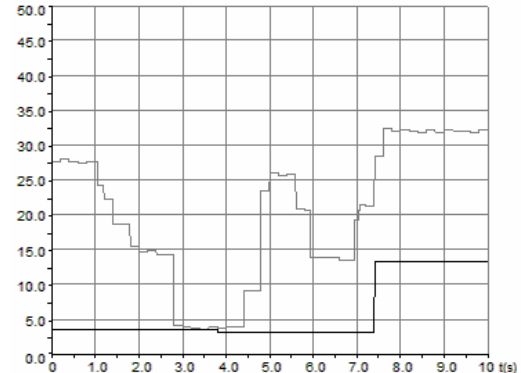
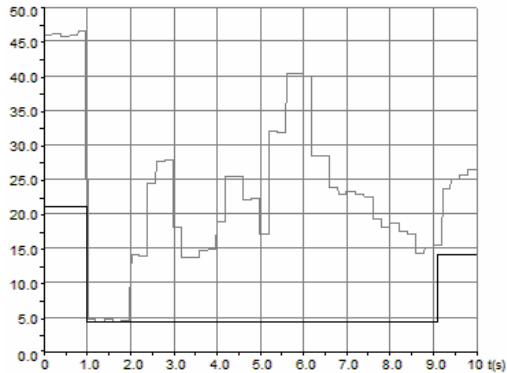

Fig. 6-9: Signal graph with Advanced Valley hold: Threshold = 30 °C (left)/ Threshold = 25 °C and Hysteresis = 12 °C (right)

6.4.2 Output Signals

If the setup dialog is open, the output- and alarm settings can be done in the window **Output signals**.

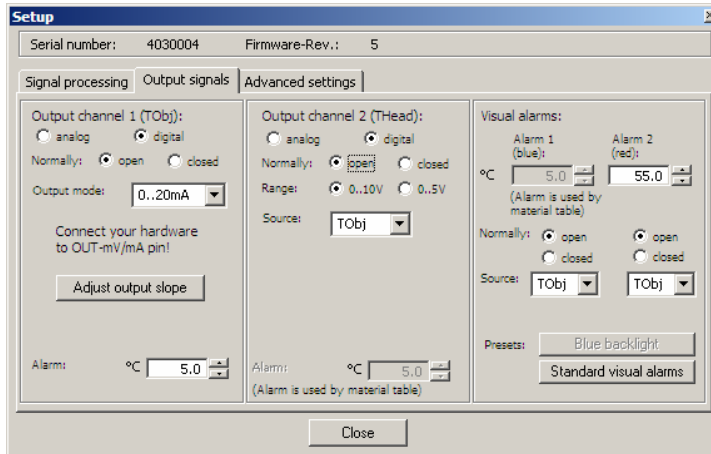

Fig. 6-10: Setup dialog – window *Output signals*

Output channel 1:

The output channel 1 is used for the object temperature. To define it as alarm output, activate **digital**. With the selection **Normally open/ closed** you can define the output as High- or Low-alarm.

Overview Alarm functions:

- Output channel 1 and 2 (if set **digital**)
- Visual Alarms (= color of LCD-Display = alarm values of the optional relais-interface)
- Software alarms (**Setup/ Display ranges**) – have only influence on the colors of the temperature display in the software screen

Edit the threshold in the menu box **Alarm** to set the trigger of the alarm.

The source of output channel 1 can not be chosen – it is always TObj (object temperature).

The following analog outputs (if **analog** is activated) are available:

- 0-5 V
- 0-10 V
- 0/4-20 mA
- Thermocouple (TCJ or TCK)

After you have selected the desired output (edit box: **Output mode**), you can adjust the temperature range of the PCE-IR10 by pushing the button **Adjust output slope**.

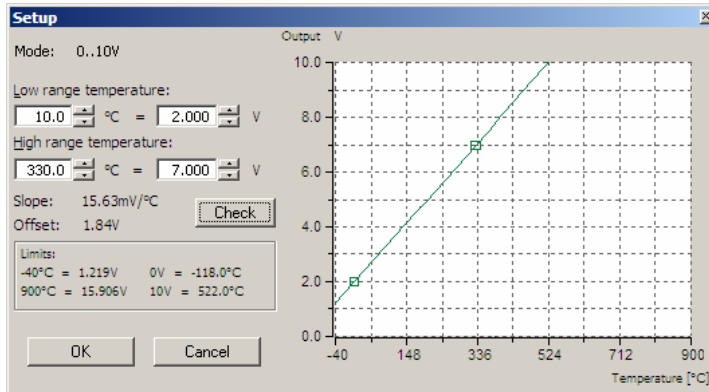

Fig. 6-11: Example for setting of the ranges

In the example (Fig. 7-11) the measurement range was defined as follows:

- $10\text{ }^{\circ}\text{C} = 2\text{ V}$
- $330\text{ }^{\circ}\text{C} = 7\text{ V}$

After you have entered the values push the **Check** button. The result will be visualized in the diagram. You may additionally check the ranges in the field **Limits** (temperature and output signal).

Output channel 2:

This channel is normally used as output for the head temperature (THead), which equals the ambient temperature. The source can also be set to TObj or TBox. The channel can also be used as alarm channel (same procedure as output channel 1).

The **Range** can be switched between 0-10 V and 0-5 V – for analog mode and alarm mode (**digital**) respectively.

Alarm 1 and 2 (Visual Alarms):

The alarms, set under **Visual alarms** are available via the optional relay interface board and as visual alarms (change of color of the LCD backlight). The selection **normally open/ close** defines the alarm as High- or Low-alarm. In **Source** you can choose between the signals TObj, THead and Tbox.

Both alarms will cause a color change of the LCD display:

- blue: alarm 1 active
- red: alarm 2 active
- green: no alarm active

In Appendix A you will find a table with all possible alarm combinations. The standard mode for the visualization of the alarms can be reset with the button **Standard visual alarms**.

The button **Blue backlight** is a presetting to achieve a permanent blue backlight on the LCD display. Pushing this button will cause the following:

- both alarms will be set to **normally open**,
- alarm limits will be set to the lower and upper measurement range limit of the connected PCE-IR10,

Now alarm 1 is permanent active [blue] and alarm 2 is permanent inactive.

All alarms (alarm 1, alarm 2, output channel 1 and 2 if used as alarm output) have a fixed **hysteresis of 2 K**.

6.4.3 Advanced Settings

If the setup dialog is open, the window **Advanced settings** allows the setting of the following parameters:

Head-parameters:

This function allows the exchange of sensing heads. The 12-digit code contains the calibration data of the head. For a correct temperature measurement make sure to enter the code (labeled on each head cable) into the electronics without mistakes. The factory setting includes the entering of the code – a change of this setting (button **Change Head Parameter**) is only necessary, if the head will be exchanged.

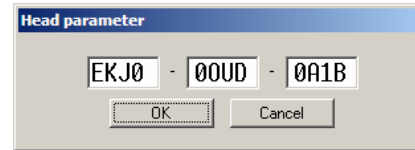
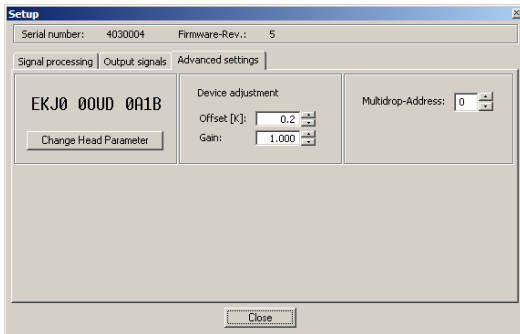

Fig. 6-12: Advanced settings – Change of the head parameters

Unit adjustment:

For certain applications or under certain circumstances a temperature offset or a change of the gain for the temperature curve may be useful. The factory default settings for **Offset** and **Gain** are:

- Offset: 0,0 K
- Gain: 1,000

Multidrop-address:

In combination with the RS485 interface you can build a network of several PCE-IR10's (max. 32 sensors). For the digital communication each sensor must have its own address.

7 Principle of Operation

Basics of Infrared Thermometry:

Depending on the temperature each object emits a certain amount of infrared radiation. A change in the temperature of the object is accompanied by a change in the intensity of the radiation. For the measurement of "thermal radiation" infrared thermometry uses a wave-length ranging between 1μ and $20 \mu\text{m}$.

The intensity of the emitted radiation depends on the material. This material contingent constant is described with the help of the emissivity which is a known value for most materials (see enclosed table emissivity).

Infrared thermometers are optoelectronic sensors. They calculate the surface temperature on the basis of the emitted infrared radiation from an object. The most important feature of infrared thermometers is that they enable the user to measure objects contactless. Consequently, these products help to measure the temperature of inaccessible or moving objects without difficulties.

Infrared thermometers basically consist of the following components:

- lens
- spectral filter
- detector
- electronics (amplifier/ linearization/ signal processing)

The specifications of the lens decisively determine the optical path of the infrared thermometer, which is characterized by the ratio **Distance to Spot size**.

The spectral filter selects the wavelength range, which is relevant for the temperature measurement. The detector in cooperation with the processing electronics transforms the emitted infrared radiation into electrical signals.

8 Emissivity

Finding the Emissivity of an Object:

The intensity of infrared radiation, which is emitted by each body, depends on the temperature as well as on the radiation features of the surface material of the measuring object. The emissivity (ε – Epsilon) is used as a material constant factor to describe the ability of the body to emit infrared energy. It can range between 0 and 100 %. A “blackbody” is the ideal radiation source with an emissivity of 1,0 whereas a mirror shows an emissivity of 0,1.

If the emissivity chosen is too high, the infrared thermometer may display a temperature value which is much lower than the real temperature – assuming the measuring object is warmer than its surroundings. A low emissivity (reflective surfaces) carries the risk of inaccurate measuring results by interfering infrared radiation emitted by background objects (flames, heating systems, chamottes). To minimize measuring errors in such cases, the installation should be performed very carefully and the sensor should be protected against reflecting radiation sources.

To determine an unknown emissivity use the following procedure:

- First, determine the actual temperature of the measuring object with a thermocouple or contact sensor. Second, measure the temperature with the infrared thermometer and modify the emissivity until the displayed result corresponds to the actual temperature.
- If you monitor temperatures of up to 260 °C you may place a special plastic sticker onto the measuring object, which covers it completely. Now set the emissivity to 0,95 and take the temperature of the sticker. Afterwards, determine the temperature of the adjacent area on the measuring object and adjust the emissivity according to the value of the temperature of the sticker.
- Cover a part of the surface of the measuring object with a black, flat paint with an emissivity of 0,98. Adjust the emissivity of your infrared thermometer to 0,98 and take the temperature of the colored surface. Afterwards, determine

the temperature of a directly adjacent area and modify the emissivity until the measured value corresponds to the temperature of the colored surface.

Characteristic Emissivities:

In case none of the methods mentioned above help to determine the emissivity you may use the emissivity table in Appendix B. These are average values, only. The actual emissivity of a material depends on the following factors:

- temperature
- measuring angle
- geometry of the surface
- thickness of the material
- constitution of the surface (polished, oxidized, rough, sandblast)
- spectral range of the measurement
- transmissivity (e.g. with thin films)

9 Maintenance

In case of problems or questions which may arise when you use the PCE-IR10, please contact our service department. The customer service staff will support you with questions concerning the optimization of the work with the infrared thermometer, calibration procedures or customer related adjustments of the product and with repairs.

The lens of the head can be cleaned with a soft, humid tissue. Never use cleaning compounds which contain solvents (neither for the head, nor for the cable and electronic box).

Appendix A – Visual Alarms

Alarm 1		Alarm 2		Alarm status		Blue LED	Green LED	Red LED	Preset
normally	temperature	normally	temperature	1	2				
Close	Below	Open	Below	1	0	On	Off	Off	Standard visual alarms
Close	Below	Open	Above	1	1	On	Off	On	Standard visual alarms
Close	Above	Open	Below	0	0	Off	On	Off	Standard visual alarms
Close	Above	Open	Above	0	1	Off	Off	On	Standard visual alarms
Close	Below	Close	Below	1	1	On	Off	On	
Close	Below	Close	Above	1	0	On	Off	Off	
Close	Above	Close	Below	0	1	Off	Off	On	
Close	Above	Close	Above	0	0	Off	On	Off	
Open	Below	Open	Below	0	0	Off	On	Off	
Open	Below	Open	Above	0	1	Off	Off	On	
Open	Above	Open	Below	1	0	On	Off	Off	Blue backlight
Open	Above	Open	Above	1	1	On	Off	On	
Open	Below	Close	Below	0	1	Off	Off	On	
Open	Below	Close	Above	0	0	Off	On	Off	
Open	Above	Close	Below	1	1	On	Off	On	
Open	Above	Close	Above	1	0	On	Off	Off	

The first four lines represent the standard mode for visualizing the alarms (in connection with TObj as source) on the LCD-display (alarm 1: Low-alarm [blue]; alarm 2: High-alarm [red]). If no alarm is activated the display color is green.

Appendix B – Emissivity Tables

METALS					
Material	Emissivity				
	1,0 μm	1,6 μm	5,1 μm	8 – 14 μm	
Aluminium	non oxidized	0,1-0,2	0,02-0,2	0,02-0,2	0,02-0,1
	oxidized	0,4	0,4	0,2-0,4	0,2-0,4
Leg. A3003, oxidized	roughened	0,2-0,8	0,2-0,6	0,1-0,4	0,1-0,3
	polished	0,1-0,2	0,02-0,1	0,02-0,1	0,02-0,1
Lead	polished	0,35	0,05-0,2	0,05-0,2	0,05-0,1
	rough	0,65	0,6	0,4	0,4
	oxidized		0,3-0,7	0,2-0,7	0,2-0,6
Chrome		0,4	0,4	0,03-0,3	0,02-0,2
Iron	oxidized	0,7-0,9	0,5-0,9	0,6-0,9	0,5-0,9
	non oxidized	0,35	0,1-0,3	0,05-0,25	0,05-0,2
	molten	0,35	0,4-0,6		
Iron, casted	oxidized	0,9	0,7-0,9	0,65-0,95	0,6-0,95
	non oxidized	0,35	0,3	0,25	0,2
	molten	0,35	0,3-0,4	0,2-0,3	0,2-0,3
Iron, forged	blunt	0,9	0,9	0,9	0,9
Gold		0,3	0,01-0,1	0,01-0,1	0,01-0,1
Magnesium		0,3-0,8	0,05-0,3	0,03-0,15	0,02-0,1
Haynes	alloy	0,5-0,9	0,6-0,9	0,3-0,8	0,3-0,8
Inconel	oxidized	0,4-0,9	0,6-0,9	0,6-0,9	0,7-0,95
	sandblast	0,3-0,4	0,3-0,6	0,3-0,6	0,3-0,6
	electro polished	0,2-0,5	0,25	0,15	0,15
Copper	polished	0,05	0,03	0,03	0,03

Material	Emissivity				
	1,0 μm	1,6 μm	5,1 μm	8 – 14 μm	
	roughened	0,05-0,2	0,05-0,2	0,05-0,15	0,05-0,1
	oxidized	0,2-0,8	0,2-0,9	0,5-0,8	0,4-0,8
Brass	polished	0,35	0,01-0,05	0,01-0,05	0,01-0,05
	rough	0,65	0,4	0,3	0,3
	oxidized	0,6	0,6	0,5	0,5
Molybdenum	oxidized	0,5-0,9	0,4-0,9	0,3-0,7	0,2-0,6
	non oxidized	0,25-0,35	0,1-0,3	0,1-0,15	0,1
Monel (Ni-Cu)		0,3	0,2-0,6	0,1-0,5	0,1-0,14
Nickel	oxidized	0,8-0,9	0,4-0,7	0,3-0,6	0,2-0,5
	electrolytic	0,2-0,4	0,1-0,3	0,1-0,15	0,05-0,15
Platinum	black		0,95	0,9	0,9
Mercury			0,05-0,15	0,05-0,15	0,05-0,15
Silver		0,04	0,02	0,02	0,02
Steel	cold-rolled	0,8-0,9	0,8-0,9	0,8-0,9	0,7-0,9
	heavy plate			0,5-0,7	0,4-0,6
	polished plate	0,35	0,25	0,1	0,1
	molten	0,35	0,25-0,4	0,1-0,2	
	oxidized	0,8-0,9	0,8-0,9	0,7-0,9	0,7-0,9
	rustless	0,35	0,2-0,9	0,15-0,8	0,1-0,8
Titanium	polished	0,5-0,75	0,3-0,5	0,1-0,3	0,05-0,2
	oxidized		0,6-0,8	0,5-0,7	0,5-0,6
Wolfram	polished	0,35-0,4	0,1-0,3	0,05-0,25	0,03-0,1
Zinc	oxidized	0,6	0,15	0,1	0,1
	polished	0,5	0,05	0,03	0,02
Tin	non oxidized	0,25	0,1-0,3	0,05	0,05

NON METALS				
Material	Emissivity			
	1,0 μm	2,2 μm	5,1 μm	8 – 14 μm
Asbestos	0,9	0,8	0,9	0,95
Asphalt			0,95	0,95
Basalt			0,7	0,7
Concrete	0,65	0,9	0,9	0,95
Iron				0,98
Soil				0,9-0,98
Paint (non alkaline)				0,9-0,95
Gypsum			0,4-0,97	0,8-0,95
Glass	plate	0,2	0,98	0,85
	melt	0,4-0,9	0,9	
Rubber			0,9	0,95
Wood, natural			0,9-0,95	0,9-0,95
Limestone			0,4-0,98	0,98
Carborundum		0,95	0,9	0,9
Ceramic	0,4	0,8-0,95	0,8-0,95	0,95
Grit			0,95	0,95
Carbon	non oxidized	0,8-0,9	0,8-0,9	0,8-0,9
	graphite	0,8-0,9	0,7-0,9	0,7-0,8
Plastic transparent	>0,5 μm		0,95	0,95
Paper (any color)			0,95	0,95
Sand			0,9	0,9
Snow				0,9
Fabric			0,95	0,95
Water				0,93